

## RESEARCH ON POLYMERIC EXTRACTION METHOD IN SAND MOLDS TO OPTIMIZE TIME AND SURFACE FINISH ON ALUMINUM CASTINGS

**Edison Patricio Abarca Pérez**

edison.abarca@epoch.edu.ec

Escuela Superior Politécnica de Chimborazo  
0000-0001-7041-4805

**Jorge Isaías Caicedo Reyes**

isaias.caicedo@epoch.edu.ec

Escuela Superior Politécnica de Chimborazo  
0000-0001-9875-6348

**Edwin Fernando Viteri Núñez**

eviteri@epoch.edu.ec

Escuela Superior Politécnica de Chimborazo  
0000-0003-3029-775X

**Jorge Sebastián Buñay Guamán**

jorge.bunay@epoch.edu.ec

Escuela Superior Politécnica de Chimborazo  
0000-0001-6963-0383

**Aquiles Santiago Reyes Romo**

ing.aquilesrr@gmail.com

Investigador Independiente  
0000-0001-7041-4805

### Abstract

The castings necessarily require final machining as they present casting imperfections. This master's thesis deals with designing a method for extracting the polymeric model in sand molds to optimize the time and surface finish in aluminum castings, avoiding final machining. The study was developed using an applied methodology, starting with modeling and 3D printing the polymeric model in PLA material. Then it is placed in the molding box and filled with the sand mixture, and the compact block is inserted into the muffle, up to a temperature of 300°C. Next, the compact block is inserted in the muffle, up to a temperature of 300°C, for 150 minutes, after which the polymeric model disintegrates, leaving the hollow cavity, to pour the molten aluminum at 800°C and let it solidify completely °C. After a quick manual cleaning, the result is a good surface finish and a notable difference in the time required to obtain it. Finally, it is recommended to apply a quantity of chloroform in equal proportion to the volume of the piece to be melted to obtain an acceptable result.

**Keywords:** extraction method; casting; molds; polymeric model.

## Resumen

Las piezas fundidas obligatoriamente requieren un mecanizado final ya que presentan imperfecciones de fundición. El presente trabajo de fin de master se refiere al diseño de un método de extracción del modelo polimérico en moldes de arena que permita optimizar el tiempo y acabado superficial en fundiciones de aluminio, evitando el mecanizado final. El estudio se desarrolló usando una metodología aplicada, se inicia con la modelación e impresión 3D del modelo polimérico en material PLA, luego se coloca en la caja de moldeo y se rellena con la mezcla de arena, el bloque compacto es insertado en la mufla, hasta una temperatura de 300°C, por un tiempo de 150 minutos, a la cual se desintegra el modelo polimérico quedando la cavidad hueca, para verter el aluminio fundido a 800°C, y se deja solidificar completamente, por último se libera la pieza fundida, luego de una breve limpieza manual se tiene como resultado un buen acabado superficial, así como una diferencia notable de tiempo en su obtención. Se recomienda aplicar una cantidad de cloroformo en igual proporción al volumen de la pieza a fundir, para obtener un resultado aceptable.

**Palabras clave:** Método de extracción; fundición; moldes; modelo polimérico.

## 1. Introduction

Producing relatively complex parts using conventional sand casting is laborious, from designing the model to produce it, because the process takes a long time. Once the element is obtained, the final step is its machining, and if the element has a complex geometry, its machining is very laborious because it presents imperfections such as burrs, suction cups, bad formations, porosity, poor surface finish, cracks, among others, as a result of all these factors, in a process that lacks precision (Kalpakjian, 2002). This study aims to develop a method for extracting the polymer model in sand molds to optimize time and surface finish in aluminum castings. First, the polymer model is obtained from 3D modeling and printing, which saves considerable time, and then the most efficient parameters of chemical mixtures and temperature are studied to obtain a good surface finish of the element in question.

## 2. Development

The parts obtained by traditional casting have defects that affect their appearance due to factors such as processing techniques, part design, and materials, in a foundry, can generate some types of defects, such as metal projections, burrs, and sand inclusions on the surfaces, these parts necessarily need final machining, and carrying out this process is tedious, since it demands a considerable use of time to obtain a geometry of optimal quality (Smith, 2006).

Given this situation, the present research seeks to innovate a method of extraction of the polymeric model in sand molds to optimize the time and surface finish in aluminum castings.

**Table 1.** Research methodology.

RESEARCH MODALITY	RESEARCH TECHNIQUES	RESEARCH INSTRUMENTS
Applied research	Prototype modeling	CAD design software
	Select the most suitable type of polymer to print the element or model to suit the process best.	3D Printer
	To analyze the best option of reaction chemical, which facilitates the process of chemical and thermal disintegration of the polymeric model and, through this, optimize the surface finish of the element.	Previous research, papers and bibliography
	Sand casting	Mold Melting furnace
	Determine the most optimal temperature parameters for the extraction of the polymeric model.	Mufla Research conducted
	Determine the difference in time and results between the traditional casting method and the innovative method.	Analysis of results

Source: Authors

### 2.1. Prototype modeling and analysis of materials for 3D printing.

#### 2. *Prototype modeling.*

For the development of this research, it was chosen to model a propeller, also known as a rotor or turbine, composed of six propellers. This mechanical device is composed of a shaft, and the vanes or blades are concentrically coupled around it. The blades are curved, the same that causes a difference in speed due to the uneven surfaces when they come into contact with a fluid. Its function is to convert the force produced by an engine into momentum to move a boat (Ecured, n.d.).

This element is beneficial as it has a wide application in different fields, such as fluid compression, and refrigeration, even a mini hydraulic generator can be built, among others. Furthermore, this machine element was chosen because of the complexity of its shape, which would result in a long production time if it were to be made using the conventional casting method, and even longer if it were mass-produced. The helix was modeled using technology revolutionizing CAD design, such as SolidWorks software. Figure 1 shows the modeled propeller.

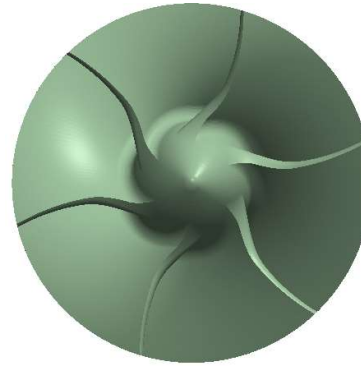
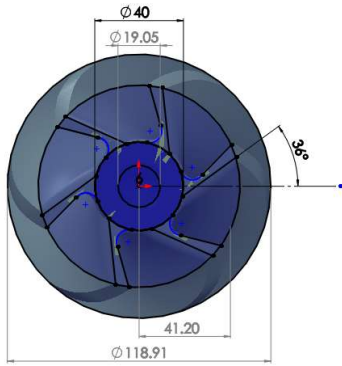

a) Digitizing the propeller in SolidWorks. b) Front view of the propeller

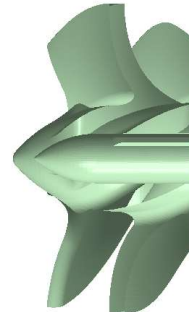
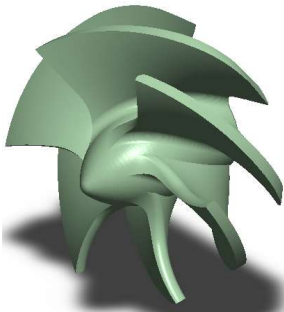

c) Isometric view of the helix d) Detail of the internal shaft.

**Figure 1:** Helix modeling in SolidWorks

Source: Own elaboration.

After the modeling in SolidWorks, it is saved in a file with the extension ".Stl" to transfer it to a 3D application software, where the configuration of the codes for their respective printing is performed, as shown in Figure 2.

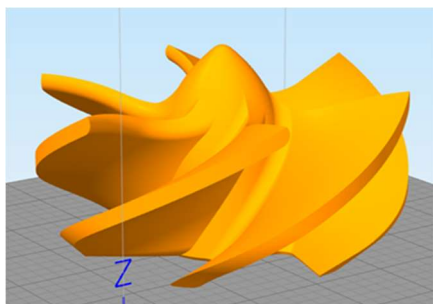

**Figure 1:** Fitting of the propeller in the 3D printing software

Source: Own elaboration

### 3. *Analysis of materials for 3D printing.*

Once the file with the ready model was obtained, it analyzed the printing materials. Within the national market, the materials available for 3D printing are ABS, PETG and PLA.

4. *Selection of the most suitable type of polymer for printing the element or model is best suited to the process.*

Based on the analysis of the existing materials in the national market for 3D printing, Table 2 summarizes the ranges of the most outstanding characteristics that directly influence the selection of the polymer that best fits the process.

**Table 2.** Summary thermal ranges of each polymer used for 3D printing.

Features	Materials		
	ABS	PETG	PLA
Price	20\$	25\$	20\$
Melting range	(95-105) °C.	(240-250)°C,	°C
Thermal decomposition	°C	°C	°C
Ecological	0%	0%	100%

Source (Printalot, 2017; TRD, 2019)

The thermal decomposition temperature is a predominant parameter for material selection. Therefore, the most suitable polymer is PLA. As shown in the table above, PLA has a higher thermal decomposition feasibility because it has the lowest temperature to achieve it.

Based on the materials mentioned above, which can be used for printing the polymeric model, PLA was selected according to the rating set out in Table 3.

**Table 3.** Material Selection Considerations

Features	Highest Rating	Materials		
		ABS	PET G	PLA
Price	3	3	1	3
Melting range	3	2	1	3
Thermal decomposition	3	2	1	3
Ecological	3	1	1	3
Total	12	8	4	12

Source: Own elaboration

As shown in the table above, the material that obtained the highest valuation is PLA since it meets the characteristics that will allow us to achieve the objective of this study. For example, the fact that it does not have high resistance to high temperatures favors its thermal decomposition when it is subjected to the different experimental temperatures, and as a consequence of this to

obtain the mold cavity, where the molten aluminum will be poured later, besides, this material is cheap and biodegradable.

## 5. Results

The following is a description of the experimental studies carried out based on different working parameters, such as chloroform application, aluminum melting temperature, polymeric model extraction temperature, and muffle mold extraction temperature, until a quality molten element is obtained.

**Table 4.** Experimental study N°1

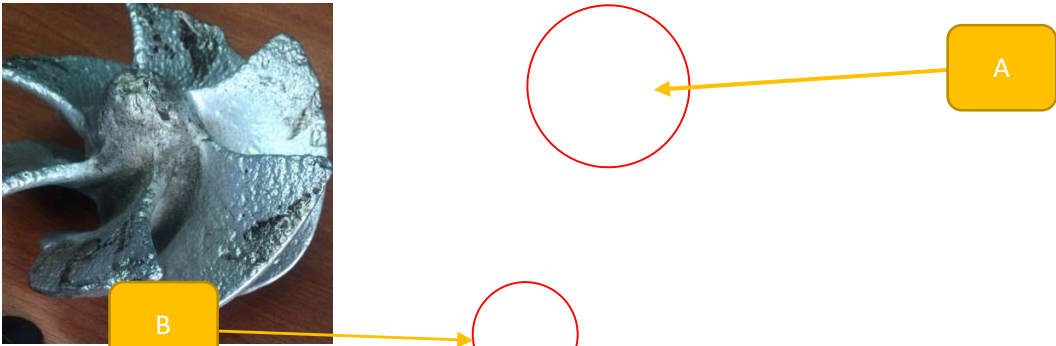
Parameters
<ul style="list-style-type: none"> <li>• Chloroform was not applied in the polymeric model.</li> <li>• Aluminum melting temperature = 600°C</li> <li>• Extraction temperature of the polymeric model = 200°C</li> <li>• Mold extraction temperature of the muffle mold = 20°C</li> </ul>
<p><b>Result:</b> In figure 3, it can be observed that it has some parts with excellent surface finish and other incomplete parts.</p> <div style="text-align: center;">  </div> <p><b>Figure 3.</b> Casting with incomplete parts  <b>Source:</b> Author</p> <p><b>Defects:</b></p> <p><b>A:</b> Incomplete surface; this is because no chloroform was applied to the surface of the polymeric model.</p> <p><b>B:</b> Incomplete fillings. Because at 200°C, the polymeric model was not completely extracted from the mold.</p>

**Source:** Own elaboration

Table 5. Experimental study N°2

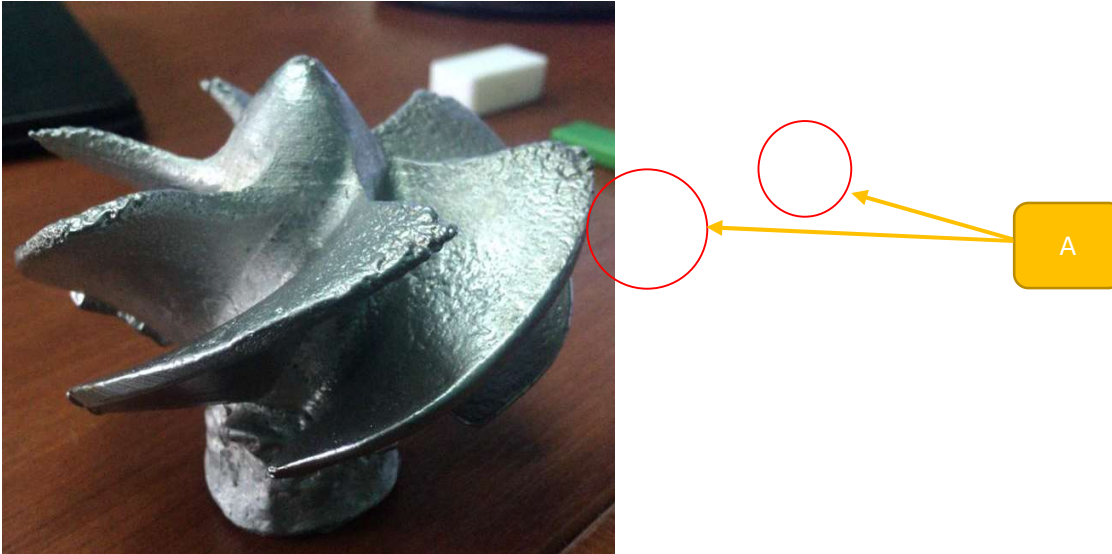
Parameters
<p>Chloroform application on the surface of the polymeric model</p> <ul style="list-style-type: none"><li>• Aluminum melting temperature = 700°C</li><li>• Extraction temperature of the polymeric model = 250°C</li><li>• Mold extraction temperature of the muffle mold = 75°C</li></ul>
<p><b>Result:</b> Figure 4 shows a remarkable improvement in the cast element but still shows some incomplete parts.</p>  <p><b>Figure 2:</b> Casting with imperfections <b>Source:</b> Author <b>Defects:</b> <b>A:</b> Incomplete geometry. - This result indicates that the experimental temperature parameters are not yet sufficient to disintegrate the PLA polymeric material entirely, and as a consequence, the material was not wholly diluted, leaving residues embedded in some parts of the mold cavity and forming this type of irregularities.</p>

Source: Own elaboration

Table 6. Experimental study N°3

Parameters

### Chloroform application on the surface of the polymeric model

- Aluminum melting temperature = 800°C
- Extraction temperature of the polymeric model = 300°C
- Mold extraction temperature of the muffle mold = 100°C

**Result:** Based on the previous studies carried out and with respect to the experimental study two, the aluminum melting temperature parameters were increased by 100°C the extraction temperature of the polymeric model was increased by 50°C and the extraction temperature of the muffle mold was increased by 25°C. The results were obtained with a complete casting without any type of irregularities, as shown in Figure 5.

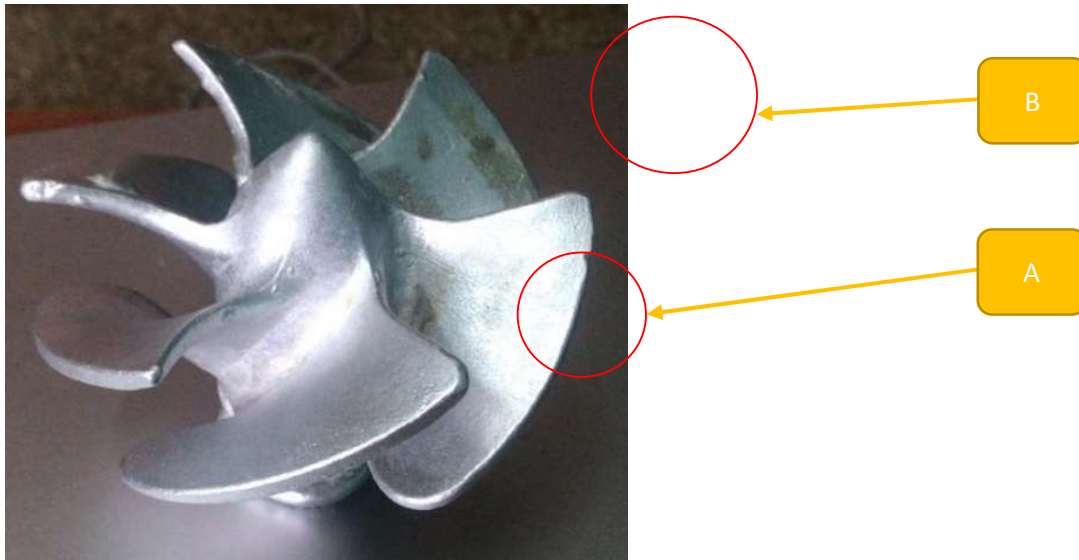

**Figure5:** Quality casting

**Source:** Authors

**A:** Good surface finish

#### **Defects:**

**B:** Soot stains on the surface. - This defect is produced by some factors such as the smoke of the foundry, and effects of the metal during the pouring, this defect can be corrected without much delay, passing lightly abrasive paper over the entire surface to remove them completely.

**Source:** Own elaboration

Figure 6 shows the final result of the cast helix.







**Figure 6:** Surface finish obtained

Source: Own elaboration

**Table 7.** Values obtained in the helix of the experimental study N 2

Number of praise	$R_a(\mu m)$			
	Roughness values		Roughness values	
1	5,786	 <p><b>Figure 7:</b> Front surface</p>	6,594	 <p><b>Figure 83:</b> Rear surface</p>
	9,953		6,340	
	7,687		4,232	
	5,462		5,422	
5	3,520	4,632		
	3,985	4,223		
<b>Total</b>	<b>36,393</b>		<b>31,443</b>	

Source: Own elaboration

Applying the formula and summing up the calculation in total sums both front and rear  $R_a = 36,393\mu m$  as well as rear  $R_a = 31,443\mu m$ . These are summed and divided for a total value of readings (n = 12) as follows:



$$R_a = \frac{a + b + c + d \dots}{n}$$

$$R_a = \frac{(36,393 + 31,443)\mu m}{12}$$

$$R_a = 5,653 \mu m$$

Table 8 shows the roughness data obtained on the surfaces of the front and rear blades (Figure 9).  $R_a = 11,792\mu m$  (Figure 9) and rear  $R_a = 18,897\mu m$  (Figure 10) of the propeller of the experimental study N3, prior to a light cleaning with a brush and fine abrasive paper.  $R_a$  value, the same procedure and formula of the previous calculation are applied:

**Table 8.** Values obtained in the helix of the experimental study N 3

Number of praise	$R_a(\mu m)$			
	Roughness values		Roughness values	
1	1,851		3,115	
	1,213		2,447	
	1,972		1,507	
	1,790		3,418	
5	1,750		4,187	
	3,216	4,223		
<b>Total</b>	11,792		18,897	

Source: Own elaboration

$$R_a = \frac{(11,792 + 18,897)\mu m}{12}$$

$$R_a = 2,557 \mu m$$

## 6. Discussion

### 7. *Time and cost differences between the traditional and innovative casting methods.*

- Time difference

Normally, the steps for the sand casting process of any element by the traditional method are shown in Figure 11.

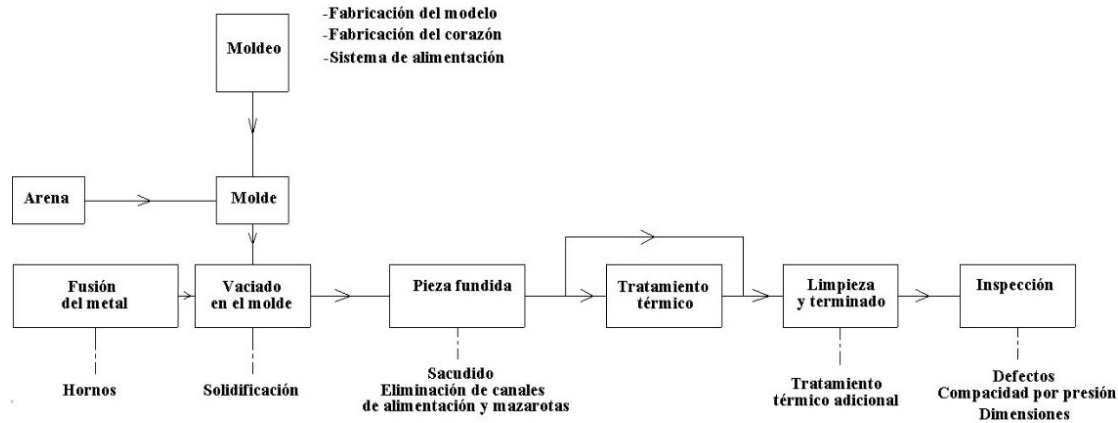

**Figure 11.** Schematic production steps in a typical sand casting operation.

**Source:** (Kalpakjian, 2002)

Here it can be seen that the process begins with the manufacture of the model, heart and feeding system, followed by the preparation of the sand to obtain the mold. On the other hand, the metal is melted in the melting furnaces, and after this, it is poured into the mold until it solidifies at room temperature, then the piece, when it is released from the sand mold, presents casting defects and obtains a quality piece it is necessary to start by eliminating the feeding channels and sprues, followed by the final machining of the same.

A part cast by the traditional method requires a very laborious and sometimes complicated task, in addition to investing considerable time to machine it and, through this, achieve to guarantee good quality in the cast part with characteristics such as good surface finish, correct dimensions and heat treatment if the part requires it.

The casting process with the innovative method presented eliminates the machining time of the piece since the direct casting is obtained, requiring only a slight cleaning of all the surfaces, which would take about three minutes, and then subjecting the piece to a heat treatment, if necessary, according to the needs intended for the cast piece.

Figure 12 shows the scheme of the most important step that the innovative method eliminates compared to a traditional method, such as the elimination of the feed channels and the risers, in addition to a high degree of processing, which are the two steps that require more attention and consequently more time and work.

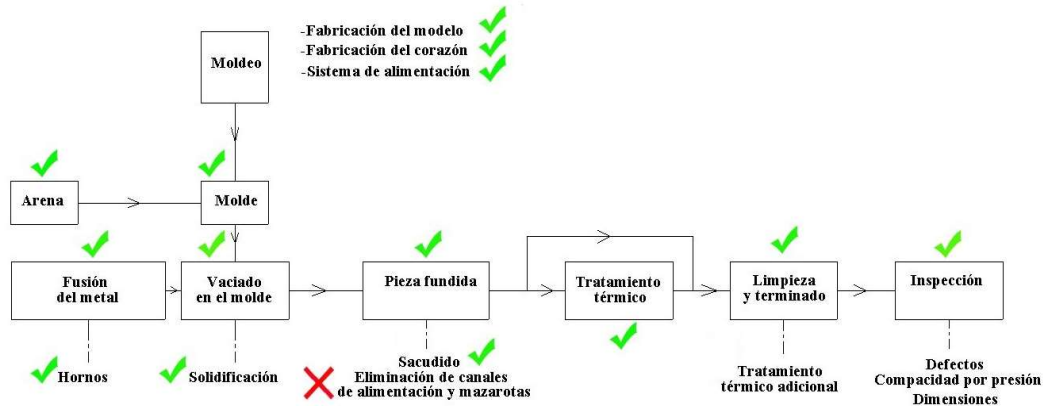

**Figure 12.** Steps discarded by innovative method for the traditional method

Source: (Kalpakjian, 2002)

Table 24 shows the time difference between the traditional, innovative and CNC machining casting methods. It can be seen that the traditional method would take a total time of 27h00, while the innovative method would take a total time of 8h00 and using a CNC machine the time would be 24h00; of these methods, the one that is more feasible to make a mass production would be the innovative one by simple logic since it is the one with the shortest time.

**Table 9.** Comparison of times according to the type of process.

Activity	Time spent for each process		
	Traditional method	Innovative method	CNC Machining
Creation of the wooden model	16h	-	
Machining time	-	-	24h
Element modeling and 3D printing		3h	
Preparation of foundry sand	4h	4h	-
Aluminum smelting	1/2h	1/2h	-
Element casting	1/3h	1/3h	-
Machining of the element obtained due to defects in the manufacturing process (the time required for machining is directly proportional to the degree of defects in the cast element).	6h	1/4h	-
<b>Total hours</b>	<b>27h</b>	<b>8h</b>	<b>24h</b>

**Source:** Authors

When the cast piece was obtained, the hypothesis raised at the beginning could be validated since, with the development of this innovative method, a piece without defects was obtained, with good surface quality, where it is no longer necessary for final machining but rather only a little cleaning with a brush all over the element to remove the residues of sand and smoke acquired in the process and then give a short pass with fine abrasive paper to refine the surface further finish as shown in Figure 13, and the casting time applying this innovative method, from the creation of the design to the obtaining of the cast piece is 08h00.



**Figure 13** Final part obtained  
**Source:** Authors

➤ Cost difference

Table 10 shows the cost differential analysis for each process.

**Table 10.** Difference in costs of each process

Materials	Smelting costs for each process		
	Traditional method	Innovative Method	CNC Machine
Carved in wood, of the model, plus labor	200\$	-	-
3D printing	-	20\$	-
Aluminum ingot	20\$	20\$	-
Wood for the boxes, plus labor for assembly.	10\$	10\$	-
Silica Sand	20\$	20\$	-
Bentonite Sand	10\$	10\$	-
Melting flux	50\$	50\$	-
Borax	5\$	5\$	-
CNC Machining	-	-	554,40
Manual machining	30\$	-	-
<b>Total costs</b>	<b>345\$</b>	<b>135\$</b>	<b>554.40\$</b>

## Source Authors

### 8. Proposal

Based on all the analyses and experimental casting studies carried out in the laboratory of the Faculty of Mechanics of the Escuela Superior Politécnica de Chimborazo, the following parameters of material, reactant chemicals and casting temperature are proposed for the application of the innovative method proposed in this master's thesis as the most optimal parameters for the casting of a propeller, these are:

- PLA selection for 3D model building
- Application of Chloroform Chemical Reactant on the entire surface of the polymeric model.
- Extraction temperature of the polymeric model of the sand mold at 300°C.
- Sand mold extraction temperature of the muffle sand mold at 100°C
- Pouring temperature of aluminum in the sand mold at 800°C

From the deduction and application of these parameters, the cast helix was obtained with good surface quality and without imperfections; as a result of this, the innovative method is validated as an efficient, fast and useful method for the traditional and CNC method existing in the national market, and in this way leave a contribution for further experimental studies as well as manufacturing companies dedicated to the field of production of parts and pieces employing aluminum casting can adopt this innovative method.

### 9. Conclusions

- Of the three polymers, ABS, PETG, and PLA, existing in the national market, the PLA polymer was selected because it does not present high resistance to high temperatures and also because it is ideal for pieces of analysis of ephemeral character (of short duration), and this is favorable for the process of decomposition of the polymeric model.
- Based on previous studies, it was determined that chloroform is a fundamental part of extracting the liquid-phase components of the PLA chemical disintegration process, and it should be applied in proportion to the volume of the model to be extracted.
- The optimum temperature parameters for this casting method were determined to be:
  - Aluminum melting temperature at 800°C
  - Extraction temperature of the polymeric model at 300°C.
  - Mold extraction temperature of the muffle mold to 100°C

The efficiency of the proposed innovative method was validated through the analysis of time and cost comparison between the traditional casting process, innovative method and CNC machining, as shown in Table 24, where the innovative method is optimal with 19 hours of difference for the

traditional method and with 16 hours for CNC machining. In terms of costs, the innovative method for the traditional method presents a saving of \$210, and for CNC machining, a saving of \$419.

## References

- Alibaba. (s.f.). *Alibaba.com*. Recuperado de [https://spanish.alibaba.com/product-detail/refining-and-degassing-of-molten-rollcastingaluminum-powder-shaped-refining-flux60693747906.html?spm=a2700.md\\_es\\_ES.maylikeexp.8.2ed71a264tuiWT](https://spanish.alibaba.com/product-detail/refining-and-degassing-of-molten-rollcastingaluminum-powder-shaped-refining-flux60693747906.html?spm=a2700.md_es_ES.maylikeexp.8.2ed71a264tuiWT)
- Avendaño et al., H. M.** (2008).
- Barkhudarov, H. y.** (2006). *Flow Science Inc, Flow 3D Manual, Mem.*
- Capello.** (1987).
- Caro Silva, F. J.** (1995). *Diseno y fabricacion de piezas fundidas .*
- Chachapoya Guevara, J. J., & Garcia Mendoza, M. I.** (2019). *Diseño y manufactura de un bloque motor monocilindrico para una motocicleta de 150c.c. con una aleación de aluminio 7075. Riobamba, Chimborazo, Ecuador .*
- Cholino Jose o, e. H. (s.f.). *Minera Jose Cholino e Hijos S.R.L.* Recuperado de <http://www.mineracholino.com.ar/producto/bentonitas-para-arenas-de-moldeo-f-40>
- Comara, S. (s.f.). *Herramientas joyeria*. Recuperado de <https://comrashop.es/ligas-productos-para-fundir/580-borax-en-polvo-envase-1kg.html>
- Dayana, M. A.** (2012). *Determinación del porcentaje óptimo de humedad de la mezcla para la elaboración del vaso inferior de la cafetera EINPUD*. Santa Clara.
- Descubrearduino. (s.f.). Recuperado de <https://descubrearduino.com/materiales-de-impresion-en-3d/>
- Djurdjevic, Z. O.-K.** (2010). Fundir control de calidad en plantas de aluminio. Ecured. (s.f.). *Ecured .* Obtenido de Ecured : <https://www.ecured.cu/H%C3%A9lice>
- Fernandez, V. M.** (2006). Proceso de fundicion en espuma perdida para la fabricacion de autopartes. *Proceso de fundicion en espuma perdida para la fabricacion de autopartes*, 1-2.
- Figuroa M, J. L.** (15 de 01 de 2009). *Fundytec de fundidor a fundidor .* Obtenido de Fundytec de fundidor a fundidor: [http://fundytec.com.mx/index.php?option=com\\_content&task=view&id=6&Itemid=6](http://fundytec.com.mx/index.php?option=com_content&task=view&id=6&Itemid=6)
- Frax, J. (s.f.). *Frax Desing*. Recuperado de <http://joelfrax.com/disenio/acabado%20superficial.html>
- Garrido Meneses, A. R., & Sanchez Taco, V. H.** (07 de 02 de 2011). *Determinacion de la metodologia para la obtencion de aleaciones de aluminio de fundicion maquinables sin porosidades*. Quito, Pichincha, Ecuador.
- Gracomaq.** (2018). *hornos vasculantes para fundicon de oro, aluminio , bronces y latones*. obtenido de hornos vasculantes para fundicon de oro, aluminio bronces y latones:

[https://www.gracomaq.net/index\\_archivos/HORNOSMETALES.htm](https://www.gracomaq.net/index_archivos/HORNOSMETALES.htm)

**Groover, M. P.** (2007). *Fundamentos de manufactura moderna*. Mexico: McGraw-Hill.

**Henson, J.** (2019). *Hacker mecanico*. Obtenido de Hacker mecanico:  
<https://hackermecanico.com/>

**Higuita Garro, J., Orlando Vásquez, O., Sepúlveda, J., & Ceballos, M.** (s.f.). Recuperado de informe #1 laboratorio de arenas. *informe #1 laboratorio de arenas*, 3-11.

**Informatica, T.** (2019). *Tecnologia Informatica*. Obtenido de Tecnologia Informatica:  
<https://tecnologia-informatica.com/impresoras-3d-que-son-como-funcionan-impresion-3d/>

**Instop.** (01 de 02 de 2108). *Instop su especialista en productos leica*. Obtenido de Instop su especialista en productos leica:  
<http://blog.instop.es/qu%C3%A9-%C3%A9s-un-escaner-laser-3d>

**Kalpakistan, R. S.** (2002). *Manufactura, ingeniería y tecnología*. Mexico: Mexicana Reg.Num.1031.

**laboratorio, E.p.**(s.f.). *ACEQUILABS*. Recuperado de <https://acequilabs.com.co/blog/guias-de-uso/que-es-una-mufla-de-laboratorio/>

**Loizaga, J. S.** (2008). Defectos metalurgicos generados por la presencia de gases en el metal fundido. 1-2.

**Medina, V. d.** (09 de 01 de 2020). *Acido Polilactico*. Obtenido de Acido Polilactico:  
<http://www.eis.uva.es/~biopolimeros/alberto/index.htm>

**Ordinola Castillo, J. C.** (2011). *caracterización de las tierras de moldeo de el porvenir de la provincia de sullana*. piura.

**Pallo Morocho, E. L., & Valdivieso Godoy, A. E.** (11 de 2018). estudio de las propiedades de las arenas y su influencia en las piezas fundidas en ciertos talleres de fundicion de la ciudad de quito. quito, pichincha, ecuador.

**Pastor, M.** (s.f.). Recuperado de *Apuntes de fundicion Epoch Riobamba*.

**Pino Tarrago, J. C., Teran Herrera, H. C., Mena mena, E. R., & Navas Medina, E.** (2015). *Calculos de fusion en la metalurgia*. Sangolqui.

**Printalot.** (27 de 02 de 2017). *Insumos para imprsion 3D*. Obtenido de insumos para impresión 3D  
<http://www.printalot.com.ar>

**Quimica, F. y.** (s.f.). *Blogdiario.com*. Recuperado de <http://jaap.blogspot.es/>

**Quipasur.** (1980). *Empresa Quipasur*. Obtenido de Empresa Quipasur:  
<http://www.quipasur.cl/fundicion/arena-para-fundicion/>

**Rodriguez, O. F.** (s.f.). Recuperado de Máquinas, Métodos y Control Dimensional del Procesamiento.

**Salcines Merino, C.** (1985). *Mezclas autofraguantes con vidrio liquido*. Habana Cuba: Pueblo Y educacion.



- Salueña Berna, X, & Napoles Alberro, A.** (2000). *Tecnologia Mecanica*. Catalunya: Ediciones de la Universitat Politecnica de Catalunya.SL.
- Schey, J. A.** (2001). *Procesos de manufactura* . Mexico: McGraw Hill.
- Silva, E.** (14 de 11 de 2019). *Propiedades y ensayos de las arenas de moldeo y noyería*. Obtenido de propiedades y ensayos de las arenas de moldeo y noyería:  
<https://es.scribd.com/document/435015193/Indice-Afs#>
- Smith, H. J.** (2006). *Fundamentos de la ciencia e ingenieria de materiales*. Mexico: McGRAW-HILL INTERAMERICANA EDITORES, S.A. DE C.V.
- Tartera, J.** (2013). Inventario de fundicion . *FUNDIPrESS59*, 41,42.  
Tecnologia.(s.f.). Recuperado de  
<https://tecnologiadelosplasticos.blogspot.com/2011/06/abs.html>
- Thirugnanam, M.** (2013). Procesos modernos de fundicion a presion a alta presion para piezas de fundicion de aluminio. 1-2.
- TRD.** (10 de 02 de 2019). *Materiales disponibles en impresion 3D*. Obtenido de materiales disponibles en impresión 3D:  
<https://www.trdimension.com/blog/materiales-impresion-3d>
- Tresdpro.** (2018). *Tresdpro*. Obtenido de Tresdpro:  
<https://tresdpro.com/que-es-el-material-pla/>
- Trimaker.** (2010). Obtenido de Trimaker:  
<https://trimaker.com/nosotros/>
- Vargas D, J.** (2015). *Dokumen*,. Obtenido de Vargas D. J:  
<https://dokumen.tips/documents/tolerancias-acabado-metrologia2015-30.html>
- Yoshihiro, A. K.** (2001). *Thermal degradation of poly[(R)-3-hydroxybutyrate]*,. Yokojama .